

Automotive & Fleet Service Equipment ↻

Battery Chargers, Starters & Testers | Exhaust Hoses & Accessories
Shop Tools & Supplies | Lubrication Equipment | Safety Products

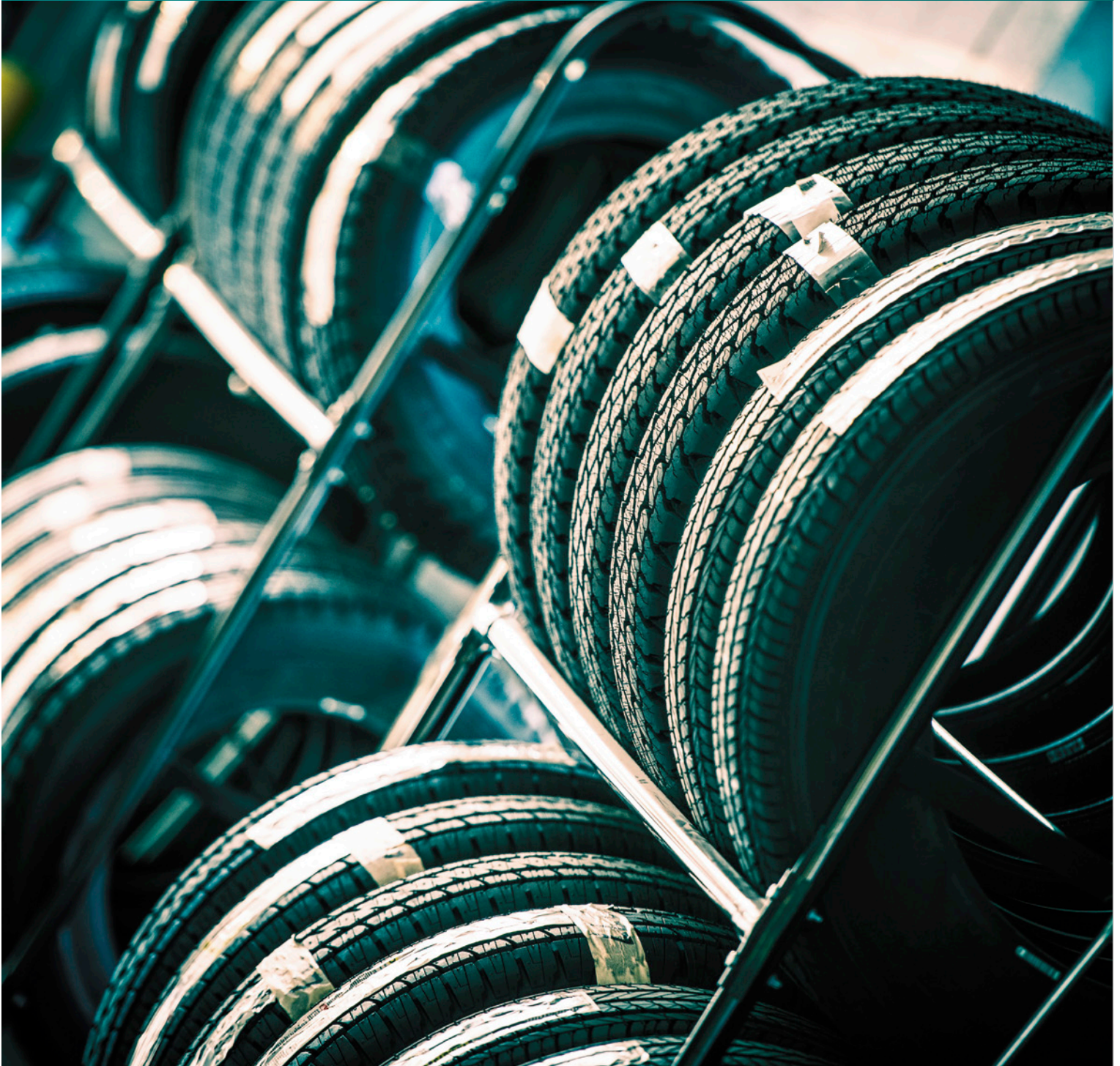



Battery Chargers & Testers

SCHUMACHER PSC-12500A

- Charges 6 and 12 volt batteries
- Fully automatic, microprocessor controlled
- 125 Amp 12V Engine Start-for emergency starting
- 15<->40 Amp 6 and 12V rapid charge with self adjusting, variable charge rates and float-mode monitoring
- 2 Amp 12V Trickle charge for small batteries
- 12V regular automotive, deep-cycle, AGM/Gel Cell and 6V regular batteries
- Built in digital volt meter/alternator tester



341-12500

ASCOT NO.	MFG. NO.	DESCRIPTION
341-12500	PSC-12500A	Schumacher PSC-12500A

SCHUMACHER INC-7A-OBDD

- On board diagnostics connector (OBDII) plugs directly into vehicles OBDII Port
- Preserves stored fault codes and programmed electronic settings
- 7 amp hour battery
- Easy to read battery status LED's tell when internal battery is at full power, 75% charged or 50% or less and needs charging
- Built-in charger for automatic charging of internal battery
- Charging and charged LED indicators indicates charging status of internal battery



341-70000

ASCOT NO.	MFG. NO.	DESCRIPTION
341-70000	INC-7A-OBDD	Schumacher INC-7A-OBDD

SCHUMACHER INC-12V-OBDD

- This accessory connector plugs the OBD II head into the car's OBD II source
- Protects vehicle fault codes, driveability codes, keyless entry codes and digital radio settings

ASCOT NO.	MFG. NO.	DESCRIPTION
343-12000	INC-12V-OBDD	Schumacher INC-12V-OBDD



343-12000

SCHUMACHER PSJ-1812

- 18 Ah professional grade, high output AGM battery
- 1800 peak amps
- 12 volt DC power outlet
- 4 gauge, 28 inch cables
- Built-in automatic charger
- Charging and charged status LEDs
- Battery status LED



341-81200

ASCOT NO.	MFG. NO.	DESCRIPTION
341-81200	PSJ-1812	Schumacher PSJ-1812

SCHUMACHER PSJ-2212

- 22 Ah professional-grade, high-output AGM battery
- 2200 peak amps, 330 cranking amps & 275 cold cranking amps
- 3-amp built-in, automatic charger
- Two-function digital display
- 12V DC power outlet
- 4-gauge, 50-inch cables



341-22120

ASCOT NO.	MFG. NO.	DESCRIPTION
341-22120	PSJ-2212	Schumacher PSJ-2212



SCHUMACHER SE-3000

▪ For heavy-duty fleet and industrial use ▪ **CHARGES A VARIETY OF BATTERIES:** 6, 12, 18 and 24 volt. No need to separately charge 18 and 24 volt batteries ▪ Full power engine start available in each volt range ▪ Fan cooled ▪ 200 amp 12 or 24 volt/180 amp 6 volt engine start for emergency starting under severe conditions ▪ Single rotary switch addresses all volt ranges ▪ “Hold” position on timer switch for continuous charging



341-03000

UL RATING:
80/60/44/30 amp
DISCHARGE RATING:
35/60/70/100 amp
CUL LISTED:
Model SF-3000

SCHUMACHER SE-6030

▪ Ideal for big fleet operations and industrial use ▪ Perfect for situations that need a lot of power (including diesel engines) ▪ Two fast charge settings ▪ Very high-output engine start assists batteries in cranking most engines under severe weather conditions ▪ For 6 and 12 volt batteries ▪ Fan cooled ▪ “Hold” position for continuous charging ▪ Durable construction with tubular handle



341-06030

UL RATING:
30 amp and 60 amp continuous, 300 amp start
DISCHARGE RATING:
40/80 amp
CUL LISTED:
Model SF-8050

MIDTRONICS HYB HYBRID BATTERY SYSTEM ANALYZER

▪ The HYB provides technicians with the capability to perform battery service maintenance testing on several leading Hybrid vehicles
▪ Simply connect the wireless convergence communication module to the vehicle’s on-board diagnostics port and follow the menu instructions on the HYB tester
▪ **ONE PERSON TEST:** Easy to use for any technician level. Consistent test across all vehicle manufacturers
▪ Safe! No exposure to dangerous high voltage ▪ **PREVENTATIVE MAINTENANCE:** Find problem packs and cells before they cause system performance issues or failure
▪ **DRIVE TEST:** Interactive, menu-driven test that uses live vehicle sensor information while performing an accelerated drive test ▪ Test 12 volt auxiliary battery ▪ Read & Clear DTC Codes ▪ **LIVE DATA:** Run Chart



342-10000

ASCOT NO.	MFG. NO.	DESCRIPTION
341-03000	SE-3000	Schumacher SE-3000

ASCOT NO.	MFG. NO.	DESCRIPTION
341-06030	SE-6030	Schumacher SE-6030

ASCOT NO.	MFG. NO.	DESCRIPTION
342-10000	HYB-1000	Tester
342-10001	HYB-1000KIT	Kit (Includes Printer)

AUTO & FLEET SERVICE // BATTERY CHARGERS & TESTERS

Service Equipment

BARTEC QUICK SERVICE TOOL

Keep your complex scan tool working on higher paying, more complicated service work, and use the QST300 instead. The QST300 is an easy to setup and easy to operate tool that resets the Change Oil Light, Relaxes the rear, electronic parking brake, and registers a new battery upon installation. The QST300 is designed to offer powerful yet affordable tool solutions for services like Oil Changes, Brake Pad Replacement and Battery Replacement.

▪ **BATTERY MANAGEMENT**

TECHNOLOGY: The QST recalibrates the necessary control modules after a battery replacement.

▪ **OIL SERVICE LIGHT RESET:** Clears the warning light on the vehicles that requires this step after an oil change.

▪ **ELECTRONIC PARKING BRAKE**

DISENGAGE: The QST300 relaxes the electronic parking brake so that brake service can be completed.

▪ **LARGE DISPLAY:** Easy to see and navigate the very intuitive operation. On screen instruction keeps the repair process moving forward.

▪ **EASY TO UPDATE:** Simply log into the QST300 update suite [free download] and keep your tool up to date. Tool comes with one year's worth of updates. For additional years, update certificates are sold separately.

▪ **BATTERIES NOT REQUIRED:** The QST300 is powered by the car through the OBDII connection.



351-30000

AUTO & FLEET SERVICE // SERVICE EQUIPMENT



The Bartec Quick Service Tool in use.

ASCOT NO.	MFG. NO.	DESCRIPTION
351-30000	QST300	Quick Service Tool for Battery, Oil and Brake Service Work



➔ Revive Engine Cleaner

REVIVE ENGINE CLEANER

A unique product for cleaning Turbo and Direct injection [GDI] engines! Revive is a water based cleaner that is sprayed into the “cold air side” of the intake system. It is very unique in that due to its chemical structure, the product is able to survive the combustion process and clean virtually anything with carbon and soot build up. It is NOT flammable and is SAFE FOR THE ENGINE! Use Revive and avoid potential tear downs.

- **GDI ENGINES HAVE A BUILT IN PROBLEM:** Because fuel is directly injected into the combustion chamber, it does not pass over the valves and other surfaces, as a result carbon builds up causing increasingly poor performance.
- **CLEANS GDI AND TURBO CHARGED ENGINES:** Revolutionary water based formula is able to survive the combustion process and clean more carbon and soot than solvent based cleaners
- **DIRECT APPLICATION:** Revive is applied directly through the cold air intake, and goes right to work on surfaces that have carbon and soot build up.
- **SAFE TO USE:** Revive is water based so no dangerous solvents or flammable liquids to worry about.



333-49900



333-49911



333-49930



333-49601



333-49602



333-49603

ASCOT NO.	MFG. NO.	DESCRIPTION
333-49900	1449-9000	Revive Engine Cleaner Kit for Engines Smaller than 5.0 Liters
333-49930	1449-9300	Revive Engine Cleaner Kit for Engines Larger than 5.0 Liters
333-49911	1449-9011	Revive Engine Cleaner Maintenance Application
333-49601	1449-6001	Countertop Display with Tri-Fold Holder
333-49602	1449-6002	Informative Counter mat
333-49603	1449-6003	Revive Product Information for Consumers

AUTO & FLEET SERVICE // SERVICE EQUIPMENT

➔ Exhaust Hoses, Tailpipe Adapters

Exhaust Hoses & Tailpipe Adapters

CRUSHPROOF EXHAUST VENTILATION SYSTEM

DOOR PORTS



391-00130 391-00125

Y-CONNECTORS



391-00240 391-00230

SPLICE CONNECTORS



391-21040 391-20040

ELBOWS



391-00430 391-00330

OVERHEAD DUCT



391-22040

Y-ASSEMBLY



391-53000

ASCOT NO.	MFG. NO.	DESCRIPTION
391-00125	DF25	2-1/2" Rubber Door Port
391-00130	ADF30	3" Aluminum Door Port
391-00140	ADF40	4" Aluminum Door Port
391-00225	RY25	2-1/2" Rubber Y-Connector
391-00230	RY30	3" Rubber Y-Connector
391-00240	AY40	4" Aluminum Y-Connector
391-20030	AC30	3" Aluminum Splice Connector
391-20040	AC40	4" Aluminum Splice Connector
391-20050	AC50	5" Aluminum Splice Connector
391-20060	AC60	6" Aluminum Splice Connector
391-21025	SP25	2-1/2" Rubber Splice Connector
391-21030	SP30	3" Rubber Splice Connector
391-21040	SP40	4" Rubber Splice Connector
391-00325	AEL25	2-1/2" Aluminum Elbow
391-00330	AEL30	3" Aluminum Elbow
391-00340	AEL40	4" Aluminum Elbow
391-00350	AEL50	5" Aluminum Elbow
391-00425	EB25	2-1/2" Rubber Elbow
391-00430	EB30	3" Rubber Elbow
391-22150	OC50D	5" Overhead Duct Connector W/Damper
391-22160	AC-60-OC	6" Overhead Duct Connector
391-22030	OC30	3" Overhead Duct Connector
391-22040	OC40	4" Overhead Duct Connector
391-22050	OC50	5" Overhead Duct Connector
391-52500	YA250	2-1/2" Y-Assembly
391-53000	YA300	3" Y-Assembly
391-54000	YA400	4" Y-Assembly

FLARELOCK HOSE

▪ For use with cars and small trucks ▪ Flared end on each length to permit connection of two or more lengths of same size hose



391-15350

ASCOT NO.	MFG. NO.	DESCRIPTION
391-15250	FLT250	2-1/2" x 11' Flarelock Hose
391-15300	FLT300	3" x 11' Flarelock Hose
391-15350	FLT350	3-1/2" x 11' Flarelock Hose
391-15400	FLT400	4" x 11' Flarelock Hose

TAILPIPE ADAPTERS

▪ Crushproof offers a complete line of accessory items



ASCOT NO.	MFG. NO.	DESCRIPTION	TAILPIPE STYLE	TAILPIPE SIZE	HOSE ID
391-93000	TPA3000	Split Adapter	Separated	Up To 2-1/2"	3"
391-90250	F250	Straight W/ Hook & Chain	Single	Up To 2"	2-1/2", 3", 3-1/2"
391-90300	F300	Straight w/ Hook & Chain	Single	Up To 2-1/2"	2-1/2", 3", 3-1/2"
391-90350	F350	Straight w/ Hook & Chain	Single	Up To 3"	2-1/2", 3", 3-1/2"
391-90400	F400	Straight w/ Hook & Chain	Single	Up To 3-12/16"	3-1/2", 4", 5"
391-90600	DSR600	Stack Adapter	Diesel Stack	Up To 5-1/2"	4", 5"
391-90606	DSR600-6	Stack Adapter	Diesel Stack	Up To 5-1/2"	5", 6"
391-91000	UNA1000	Plug-n Unihose	All	All	3"
391-90475	F475	Oval Adapter (2.5" x 6")	Twin Oval	2", 5-1/2"	3", 4"
391-90575	F575	Oval Adapter (3.5" x 8.5")	Twin Oval	2", 5-1/2"	3", 4"
391-91250	RA250	Bell w/Snaps	All	All	3"
391-91300	RA300	Bell w/Snaps	All	All	3"

AUTO & FLEET SERVICE // EXHAUST HOSES, EXHAUST EXTRACTION



Vehicle Exhaust Extraction

PORTABLE EXHAUST REMOVAL SYSTEM

This easy to use portable exhaust extraction system is a practical and affordable solution for effectively removing toxic exhaust fumes from auto repair facilities, motorcycle shops, small engine repair shops and other work areas where toxic fume removal is needed.

- **Positioned next to the vehicle, the high-output suction fan captures fumes and discharges them safely up to 30' away**
- 3/4 HP fan produces 330 CFM air flow
- Uses standard 100V current
- Fan is mounted in tough, integrally molded polyethylene "flow thru" case
- Mobile base makes the EV-5100 easy to position behind the vehicle or move around the shop
- Height position is controlled by a quick-release spring-loaded cam lock
- 30' discharge hose stores easily and neatly when not in use



391-05100

ABOVE GROUND/RAIL SYSTEM

The streamlined, euro-style design will enhance the appearance of your service area.

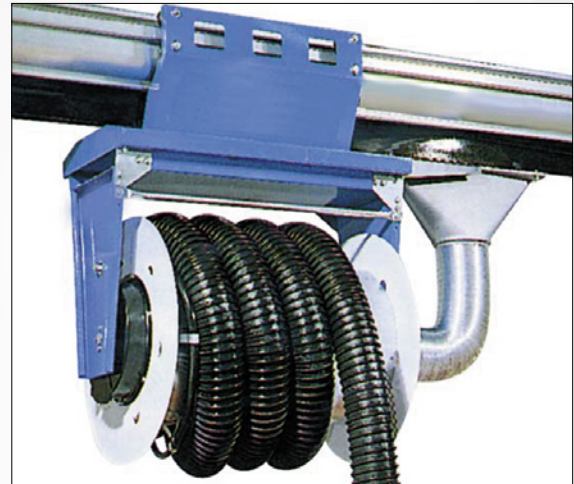

Sliding crabs eliminate the need for overhead drops at every service bay. They are easily positioned wherever needed.

LIMITLESS FLEXIBILITY: Modular design uses an extruded aluminum exhaust rail and a sliding ventilation crab

- Sliding crab is equipped with an exhaust hose and tailpipe adapter and rolls along the rail
- Easily sized to fit any workspace and adapts quickly to changing needs

MAXIMUM EFFICIENCY, MINIMAL OPERATION COSTS:

- High-efficiency exhaust fan quietly and effectively removes fumes
- Fewer outlets required to cover all of the service bays
- Slides easily out of the way when not in use
- Fewer hose drops and a smaller exhaust fan saves money and reduces energy consumption



VIRTUALLY MAINTENANCE FREE: Easily sized to fit any workspace.

FREE: Rugged aluminum rail design is virtually maintenance free and holds up under heavy use

- No PVC or cast iron pipes to flood, freeze or break

EASE OF USE: Sliding crab system makes it easy to position a drop at any service bay and attach it to the vehicle

- Hoses retract easily when not in use

REDUCES INSTALLATION TIME: Most systems can be engineered using eight basic components

- The "bolt-together" design significantly reduces installation time

ENHANCED PROFESSIONAL IMAGE: Retractable hoses create an organized professional workspace

ASCOT NO.	MFG. NO.	DIMENSIONS	MOTOR	HOSE	WEIGHT
391-05100	EV-5100	24"W x 24"D x 35"H	3/4 HP 330 CFM	30'	86 Lb.

AUTO & FLEET SERVICE // EXHAUST HOSES, EXHAUST EXTRACTION

➔ Bench Grinders, Shop Vises

Bench Grinders & Shop Vises

INDUSTRIAL BENCH GRINDERS



- **UL listed motor** ▪ Pre-lubricated and enclosed ball bearings ▪ Cast iron wheel guards and dust vents ▪ One piece quick adjusting spark guards ▪ Large eye shields with quick adjustment ▪ Adjustable tool rests
- Heavy duty guarded toggle switch on 8" and 10" ▪ Fine and coarse vitrified wheels included ▪ Rubber mounts prevent movement
- 3-conductor cord with 3-prong plug

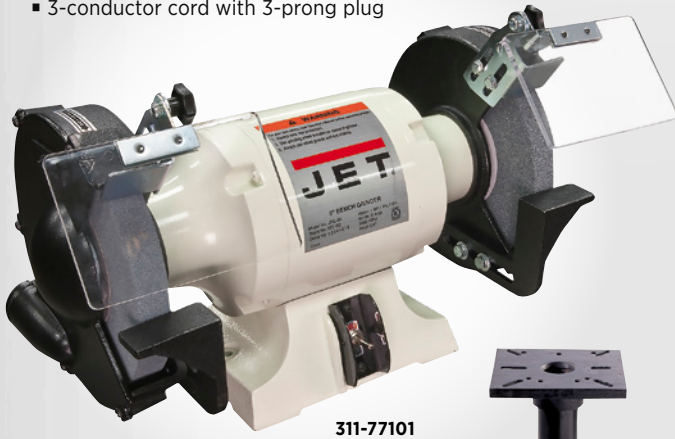

311-77101



311-77172

ASCOT NO.	MFG. NO.	DESCRIPTION
311-77101	577101	JBG-6A: Bench Grinder, 6" Wheel
311-77102	577102	JBG-8A: Bench Grinder, 8" Wheel
311-77103	577103	JBG-10A: Bench Grinder, 10" Wheel
311-77172	577172	JPS-2: Optional Pedestal

BENCH GRINDER MODELS AT A GLANCE

	MFG. NO.	577101	577102	577103
	ASCOT. No.	311-77101	311-77102	311-77103
Overall Dimensions (LxWxH)		18"x10.5"x8.5"	19"x12.5"x13"	24.5"x12.25"x13"
Wheel Size (DxWxB)		6"x7.5"x5"	8"x1"x5.75"	10"x1"x1"
Motor		1/2 HP 1 Phase 115V	1 HP 1 Phase 115V	1.5 HP 1 Phase 115V
Amperage (Full Load):		5-1/2	8-1/2	10-1/2
Amperage (No Load):		4	5	7
Cycle		60	60	60
RPM		3,450	3,450	1,725
Wheels Included		36/60 Grit	36/60 Grit	24/46 Grit
Net Weight		32 Lbs.	54 Lbs.	110 Lbs.
Shipping Weight		38 Lbs.	68 Lbs.	119 Lbs.

PROFESSIONAL SHOP VISES



- **Cast iron jaw with heavy internal ribs for added strength.** **Pipe jaws are permanently cast in for greater channel strength** ▪ Cast iron back jaw designed for exceptional alignment with the front jaw
- "V" notched, replaceable/reversible jaws made of carbon steel and heat treated for extra strength ▪ Specially designed spring loaded handle and screw guarantees quick jaw response
- Front jaw beam covers and protects screws ▪ Steel handle balls forged from handle stock



311-64055

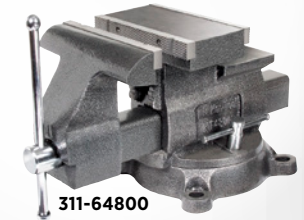

311-64800

ASCOT NO.	MFG. NO.	JAW WIDTH	JAW OPENING	THROAT DEPTH	PIPE CAP.	WEIGHT
311-64055	64055	5-1/2"	6-1/2"	3-3/16"	1/8"	30 Lbs.
311-64065	64065	6-1/2"	7-1/2"	3-3/4"	1/8"-2-1/2"	41 Lbs.
311-64650	64650	6-1/2"	7"-10"	3-3/16"	1/8"-2-1/2"	50 Lbs.
311-64800	64800	8"	8"-11"	3-3/4"	1/8"-3"	74 Lbs.

5" TRADESMAN VISE

- **Wider jaws provide greater clamping surface** ▪ Fully enclosed spindle and nut increases the life of the vise ▪ Made from 60,000 PSI tensile ductile iron ▪ Precision turned sidebar ▪ 360° swivel base with double lockdowns
- **OPENING CAPACITY MAX: 5"**



311-63200

ASCOT NO.	MFG. NO.	JAW WIDTH	THROAT DEPTH	PIPE CAP.	WEIGHT
311-63200	63200	5-1/2"	3-3/4"	1/4 - 3	51.55 Lbs.

6" SWIVEL BASE BENCH VISE

- **Heavy duty 30,000 PSI castings for long life and added strength** ▪ Swivel bar rotates 360° and has double lockdowns ensuring maximum stability ▪ Powder coat paint resists scratches and provides a tough durable finish ▪ Replaceable hardened steel top and pipe jaws



311-21500

ASCOT NO.	MFG. NO.	JAW WIDTH	THROAT DEPTH	PIPE CAP.	WEIGHT
311-21500	21500	6"	4-1/8"	1/4 - 3-1/2	69.35 Lbs.

AUTO & FLEET SERVICE // SHOP TOOLS, SUPPLIES & EQUIPMENT

Pliers & Screwdrivers



7" CUTTING PLIER WITH END CUTTER

- **Perfectly mated cutter, heat treated to hold its edge** ▪ Polished high carbon drop forged steel
- CHANNELLOCK BLUE® comfort grips

ASCOT NO.	MFG. NO.	DESCRIPTION
319-00357	357	7" Cutting Plier with End Cutter



319-00357

5" CUTTING PLIER, BOX JOINT

- **Perfectly mated cutters, scientifically heat treated to hold their edge** ▪ Precision made of fine polished, high carbon drop forged steel
- Distinctive CHANNELLOCK BLUE® comfort grips

ASCOT NO.	MFG. NO.	DESCRIPTION
319-00435	435	5" Cutting Plier, Box Joint



319-00435

6" DIAGONAL CUTTING PLIER, BOX JOINT

- **Perfectly mated cutter, heat treated to hold its edge** ▪ Polished, high carbon drop forged steel
- Distinctive CHANNELLOCK BLUE® comfort grips

ASCOT NO.	MFG. NO.	DESCRIPTION
319-00436	436	6" Diagonal Cutting Plier, Box Joint

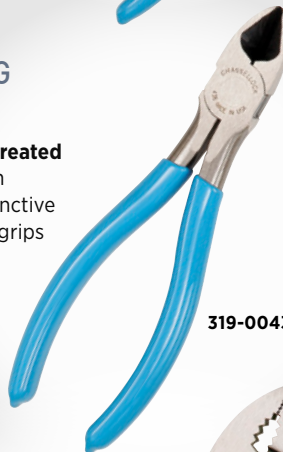

319-00436

6" SLIP JOINT PLIER, WIRE CUTTING SHEAR

- **Thick Nose Pliers** ▪ Shear-type wire cutter
- Precision made of fine polished, high carbon drop forged steel
- Patented PermaLock® fastener eliminates nut and bolt failures
- CHANNELLOCK BLUE® comfort grips

ASCOT NO.	MFG. NO.	DESCRIPTION
319-00526	526	6" Slip Joint Plier, Wire Cutting Shear



319-00526

SLOTTED SCREWDRIVER

- Tip Width: 1/4" ▪ Blade Length: 6" ▪ Handle Length: 4" ▪ Overall Length: 10" ▪ Bulk Packaged
- **MADE IN THE USA**

ASCOT NO.	MFG. NO.	DESCRIPTION
319-09125	029A66S	Slotted Screwdriver



319-09125

#2 PHILLIPS SCREWDRIVER

- **Cushion Grip for comfort** ▪ Blade Length: 4" ▪ Handle Length: 4.5" ▪ Overall Length: 8.5" ▪ Bulk Packaged
- **MADE IN THE USA**

ASCOT NO.	MFG. NO.	DESCRIPTION
319-09144	R44PGB	Slotted Screwdriver



319-09144

1/4" SOCKET DRIVER

- **Shank made from chrome vanadium** ▪ Overall Length: 6" ▪ Shank Length: 2-1/2" ▪ Ideal for use with the TPMS 11mm x 12mm flip socket
- Screwdriver handle, made from durable plastic-like material
- **MADE IN THE USA**

ASCOT NO.	MFG. NO.	DESCRIPTION
319-72521	7252100	1/4" Socket Driver with Screwdriver Handle



319-72521

8-PIECE PROFESSIONAL SCREWDRIVER SET

- **Includes 5 flat tip drivers and 3 Phillips tip drivers:**

SLOTTED: 3/8" x 8", 5/16" x 6", 1/4" x 4", 3/16" x 3", 1/4" x 1-1/2"

PHILLIPS: #2 Phillips x 4", #1 Phillips x 3", #2 Phillips x 1-1/2"

- Black handles ▪ Hardened chrome vanadium shafts
- Vapor blasted magnetic tips ▪ Packaged in molded plastic tray for storage
- Hex bolsters for extra turning power



ASCOT NO.	MFG. NO.	DESCRIPTION
319-19800	19800	8-Piece Professional Screwdriver Set

319-19800

AUTO & FLEET SERVICE // SHOP TOOLS, SUPPLIES & EQUIPMENT

➔ Tire Dunkers, Squeegees, Brushes

Shop Cleaners & Brushes

HEAVY DUTY TUBELESS TRUCK TUBE/TIRE DUNKERS

▪ **Space saving design requires 40% less space** ▪ New design fits in left or right corners ▪ Entire rim and tire are checked for air leaks simultaneously ▪ One man operation: Safe and easy to operate, no lifting ▪ 360° turn in water: Easy and fast inspection ▪ Uni-quick ratchet type adapter adjusts from 15" dia. to 52" dia. and instantly lifts up to 400 lbs. RVs to super singles ▪ Optional inner tube adapter allows you to check tubes up to 50" in diameter

MOV-IT TIRE PRODUCTS ○ ○ ○



517-00039

517-00055

SPACE SAVING DESIGN

ASCOT NO.	MFG. NO.	DESCRIPTION
517-00100	100TTD	E-Z Dunk Truck Tire Dunker, Range 15" - 50" Diameter
517-00039	39ED	39" Dia. x 24" Depth Passenger & RV Tube & Tire Dunker with Polyethylene Tank
517-00055	55T	T & G 55" Dia. x 24" Depth Truck & Grader Tube Dunker with Polyethylene Tank

FLOOR SQUEEGEES

▪ **Black neoprene rubber blade designed for rough, heavy use** ▪ *Handle not included, order separately*



395-45507

ASCOT NO.	MFG. NO.	DESCRIPTION
395-45507	45507	24" Straight Squeegee
395-45509	45509	Blade Refill for 45507
395-44020	44020	Handle

PALMYRA FILL GARAGE BRUSHES/BROOMS

▪ **Excellent for heavy duty sweeping of concrete, sidewalks and garage floors** ▪ Can be used for wet or dry sweeping



395-42023

ASCOT NO.	MFG. NO.	DESCRIPTION
395-42023	42023	24" Garage Brush-Palmyra

PLASTIC HANDLED BRASS SIDEWALL BRUSH

▪ **Densely packed brass bristles** ▪ Great for cleaning white sidewall tires ▪ **BRISTLE LENGTH:** 3/4" ▪ **OVERALL LENGTH:** 8-1/4" ▪ Plastic handle fits comfortably in the hand



395-13124

ASCOT NO.	MFG. NO.	DESCRIPTION
395-13124	VT-932	Plastic Handled Brass Sidewall Brush

WOODEN HANDLED WIRE BRUSH WITH METAL SCRAPER

▪ **Cleans rust from rims and wheels** ▪ 19 rows of steel bristles ▪ Slightly curved wooden handle ▪ *Metal scraper included* ▪ **BRISTLE LENGTH:** 1" ▪ **OVERALL LENGTH:** 14-1/4"



535-00150

ASCOT NO.	MFG. NO.	DESCRIPTION
535-00150	VT-931	Wooden Handled Wire Brush with Metal Scraper

AUTO & FLEET SERVICE // SHOP TOOLS, SUPPLIES & EQUIPMENT

➔ Hand Cleaners, Hand Scrub

GOJO SUPRO MAX™ 2000

▪ Removes tough, sticky soils while being gentle on the skin ▪ A unique blend of cleaners, skin conditioners and gentle scrubbers ▪ Does not leave a residue or dry out the skin



395-72722

ASCOT NO.	MFG. NO.	DESCRIPTION
395-72722	7272-D2	PRO™ 2000 Starter Kit (1 Dispenser, 1 Refill)
395-72724	7272-04	PRO™ 2000 Refill (4 Per Case)

GOJO NATURAL ORANGE PRO

▪ Quickly removes most common medium to heavy soils ▪ Contains pumice scrubbing particles to help loosen stubborn dirt ▪ Natural citrus ingredient leaves pleasant scent ▪ 2000ml capacity



395-72552

395-72554

ASCOT NO.	MFG. NO.	DESCRIPTION
395-72552	7255-D2	Orange PRO™ Starter Kit (1 Dispenser, 1 Refill)
395-72554	7255-D4	Orange PRO™ Refill (2 Per Case)

GOJO NATURAL 1-GALLON PUMP BOTTLE



395-09552

ASCOT NO.	MFG. NO.	DESCRIPTION
395-09552	0955-02	2x 1-Gallon Pump Bottles

SUPER TOUGH HAND SCRUB

▪ Rids hands of dirt and grease while leaving the skin soft and chap free ▪ Solvent free ▪ Soft polymer scrubbers ▪ Economical ▪ Contains skin moisturizers ▪ Clean fragrance ▪ Never irritates or burns open wounds ▪ Rinses clean ▪ Keeps your sink clean ▪ Keeps your pipes clean ▪ Will not separate during hot months ▪ Long shelf life ▪ Neutral pH



395-00101



395-00125



395-06400

ASCOT NO.	MFG. NO.	DESCRIPTION
395-00101	TS1GAL-WP	1-Gallon Container with Hand Pump
395-00125	TS-125	Wall Mount Dispenser
395-06400	TS64000	64-Ounce Container, recommended for shops with under 10 users

AUTO & FLEET SERVICE // SHOP TOOLS, SUPPLIES & EQUIPMENT

➔ Shop Lights, Static Cling Printer, Service Stickers

Shop Lights & Service Stickers

RECHARGEABLE WATERPROOF WORK LIGHT



▪ **Best in the industry, Ascot Supply Corporation's Rechargeable Waterproof Work Light is the brightest rechargeable work light available with its powerful 66 LED's (460 lumens)** ▪ Swivel hook for hanging ▪ Universal attachment hook can be used as a light stand or attached under a car hood ▪ Rechargeable battery ▪ *Replacement 12 V lighter adapter is also available and sold separately*



312-05224

ASCOT NO.	MFG. NO.	DESCRIPTION
312-05224	CED5224A-AS	Rechargeable Waterproof Work Light
312-15224	CED522P3-AS	Replacement AC Adapter for Rechargeable Waterproof Work Light
312-25224	CED5224PI-AS	12V Lighter Adapter for Rechargeable Work Light



BOUNCE LITE

▪ **Bounces instead of breaking** ▪ Patented rough service bulb for superior impact resistance ▪ 18/2 SJTOW cord for longer cord life ▪ Fully enclosed safety switch



312-12010

ASCOT NO.	MFG. NO.	DESCRIPTION
312-12006	12006	Bounce Light 25' Cord
312-12010	12010	Bounce Light on 40' Reel
312-11006	11006-17	Replacement Rough Service Bulb

STATIC CLING PRINTER

▪ **Full feature Reminder Sticker Solution takes professionalism to a new level** ▪ Zebra Printer pre-programmed to work out of the box ▪ Zebra Keyboard Display Unit ▪ **1 year parts and labor warranty** (6 months on print head) ▪ **INCLUDES:** 1 ribbon, Zebra CD with Drivers for printer and Create-A-Label Software



399-11111

ASCOT NO.	DESCRIPTION
399-11111	Static Cling Printer

STATIC CLING REMINDER STICKERS

▪ **Excellent item to promote repeat business** ▪ Keeps your name, the service to be done and the time to do it in constant view of the customer ▪ More effective than a door jam sticker ▪ Static cling vinyl will cling to almost any smooth surface ▪ No adhesive residue and they can be removed for cleaning and replacing ▪ Silk screen printing process for a high quality image and a writing strip that won't allow the ink to fade ▪ Generic design stickers as well as personalized stickers



399-00102

399-00101

399-00103

ASCOT NO.	DESCRIPTION
399-00101	Air Pressure/Tire Rotation Static Cling Sticker
399-00102	Oil Change Static Cling Sticker
399-00103	Service Reminder Static Cling Sticker

AUTO & FLEET SERVICE // SHOP TOOLS, SUPPLIES & EQUIPMENT

Tire Displays, Racks & Carts

PASSENGER & LIGHT TRUCK FOLDING RACK

- **Flexible & mobile, this system helps you keep tire handling to a minimum and offers unparalleled versatility**
- It allows you to store a large number of tires when they are placed in a laced pattern but it also can be used for fewer tires if they rest on the tread
- The racks are made of heavy duty steel and are built for superior durability



751-03260

ASCOT NO.	MFG. NO.	CAPACITY	DIMENSIONS
751-03260	MLTFD	32-60 Tires	72" x 50" x 66"

PASSENGER & LIGHT TRUCK STACKING RACK

- **This versatile, modular storage system offers enormous flexibility in the layout of your tire warehouse**
- The racks are mobile and stackable, allowing you to move them quickly
- This system is ideal for storing a large number of tires
- The removable posts let you stack the bases - which can be covered by wire mesh or a perforated plate - **reducing the space taken up by the racks by 80%**



751-06060

ASCOT NO.	MFG. NO.	CAPACITY	DIMENSIONS
751-06060	MSR-6060	28-35 Tires	60" x 60" x 60"

3, 4 AND 5-TIER TIRE SHELVING

- **This storage system is ideal for areas where a forklift cannot be used since it is designed to maximize upright tire storage**
- This system is mainly used to store a small number of tires or store customers' tires
- **THREE ADJUSTABLE TIERS:**



751-00092

- Perfect for tires alone or wheel-mounted
- Allows for storage of 330 tires in a 40-foot container
- *Fasteners for walls, floors and additional sections are included*
- Holds 10-12 tires per level
- Rails are tilted to hold tires properly
- Each section is designed to stand alone

ASCOT NO.	MFG. NO.	CAPACITY	DIMENSIONS
751-00092	MTS-92	30 to 36 tires	92" X 92" X 18"
751-00924	MTS-924	40 to 48 tires	92" x 18" x 120"
751-00925	MTS-925	50 to 60 tires	92" x 18" x 150"

WALL GRID SYSTEM

- **Holds 8 tires/wheels**
- **WEIGHT:** 57 lbs.
- Packaged in a cardboard box
- *Replacement grids and hooks available separately*

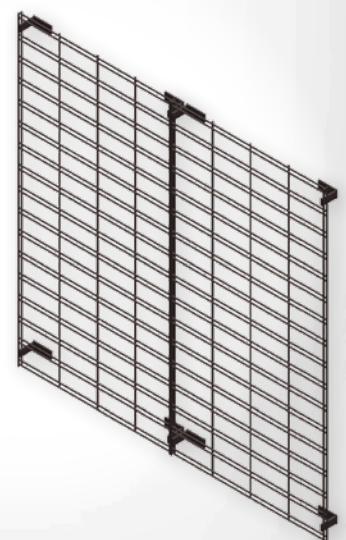
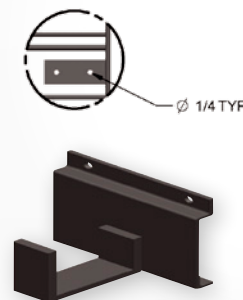

ASCOT NO.	MFG. NO.	DESCRIPTION
751-24481	MWG-2448-KIT	Wall Grid Tire & Rim Display (Complete Kit)
751-24482	MWG-2448-G	Wall Grid Tire & Rim Display (Set of 2 Grids)
751-24483	MWG-2448-H	Wall Grid Tire & Rim Display (Set of Hooks)

AUTO & FLEET SERVICE // SHOP TOOLS, SUPPLIES & EQUIPMENT

➔ Tire Displays, Tire Racks

Tire Displays, Racks & Carts (cont.)

WALL MOUNT TIRE RACK

▪ Get bulky tires out of your work space. The wall mount tire rack lets you store eight tires on the wall and keep your floor tire-free ▪ Easy to assemble and install on a wooden or concrete wall



751-00066

ASCOT NO.	MFG. NO.	CAPACITY	DIMENSIONS
751-00066	MWM-66	8 Tires	66" Long

TRUCK TIRE FOLDING RACK

▪ For greater ease of use in storing and handling your tires for heavy trucks or farm machines, this folding rack offers vertical tire storage for easy access ▪ Each rack holds 8 tires and can be stacked 4 high, or 20 high when folded ▪ Fits easily in a trailer for shipping



751-08010

ASCOT NO.	MFG. NO.	CAPACITY	DIMENSIONS
751-08010	MTFR	8-10 Tires	94" x 44" x 52"

STANDARD TIRE DISPLAY ON CASTERS

▪ The standard tire display is 60" long and holds up to 14 tires, 7 on each of 2 tiers ▪ This model is used a great deal by Goodyear and Michelin ▪ With 2 wheels and 2 steel feet, moving this rack requires the display truck. The truck acts as a lever, facilitating handling in snow, on gravel surfaces and on inclines



751-00060

ASCOT NO.	MFG. NO.	CAPACITY	DIMENSIONS
751-00060	MTD-60	10-14 Tires	60" x 72" x 20"

3-TIER TIRE DISPLAY

▪ This display unit mounted on two fixed wheels can hold 21-30 tires with rims ▪ Handling requires a dolly designed specifically for wheel-mounted tire display units ▪ It is 60" long (1524 mm) and ideally suited for heavier loads and uneven ground ▪ Comes with a logo plate (48" x 12") painted black to put your logo



751-00272

ASCOT NO.	MFG. NO.	CAPACITY	DIMENSIONS
751-00272	MTD-3T	21-30 Tires	60" Long

DELUXE TIRE DISPLAY ON CASTERS

▪ Provides an excellent compromise between strength and lightness ▪ Equipped with casters that let you move it quickly and easily ▪ Allows you to store 16 tires with an outside diameter of up to 31"



751-00072

ASCOT NO.	MFG. NO.	CAPACITY	DIMENSIONS
751-00072	MTD-72	14-18 Tires	72" x 75" x 20"

WHEEL DISPLAY

- Will hold up to 8 wheel rims
- Rims can be as large as 27" in diameter and 12" wide
- Gives your customers rims visual exposure
- Made with 1½" (28mm) round tube with brushed stainless steel finish
- Fully adjustable in height



751-00093

ASCOT NO.	MFG. NO.	CAPACITY	DIMENSIONS
751-00093	MWD	4-8 Tires	24" x 24" x 78"

STANDARD SHOWROOM DISPLAY

- This economical tire display holds 6 tires
- Because of its height, it uses very little floor space – just 4 square feet
- The tires are suspended on display hooks provided in strategic positions
- The base of this tire display consists of 3 legs made of laser-cut steel for increased accuracy and stability



751-00773

ASCOT NO.	MFG. NO.	CAPACITY	DIMENSIONS
751-00773	MSSD	6 Tires	90" High

FOUR TIRE ROLLING DISPLAY

- Display holds 4 tires: 3 at the bottom and 1 on top
- Rigid wheels for ease of mobility
- Weight: 45 Lbs.
- Shipped in a cardboard box
- Units are equipped with blank signs for customized logo



751-00044

ASCOT NO.	MFG. NO.	CAPACITY	DIMENSIONS
751-00044	MWD	4 Tires	38" x 27" x 44"

DELUXE SHOWROOM TIRE DISPLAY

- Ideal for showing your tires to your customers
- Can hold eight tires with a diameter of up to 29"
- Complete with a pamphlet holder and 15 sliding strips of major tire brands



751-00008

ASCOT NO.	MFG. NO.	CAPACITY	DIMENSIONS	COLOR
751-00008	MSTD-R	8 tires	35" X 98" X 34"	Red
751-00018	MSTD-N	8 tires	35" X 98" X 34"	Black

DOLLY FOR TIRE DISPLAYS

- Required to handle tire display units
- Only one is necessary even if you have several display units
- Compatible with all other makes of display units



751-00172

ASCOT NO.	MFG. NO.	DESCRIPTION
751-00172	MD	Dolly for Tire Displays

→ Tire Carts

Tire Displays, Racks & Carts (cont.)

TIRE CART

- **Easy to maneuver, even with a full load of tires** ▪ Can handle tires up to 35" in diameter ▪ Features a gas spring that automatically closes the arms and grips the tires
- All you have to do is to push down on the pedal, slide the cart under the stack of tires and release the pedal. The frame lines up the tire on its own ▪ Allows you to move tires 16 to 35 inches in size

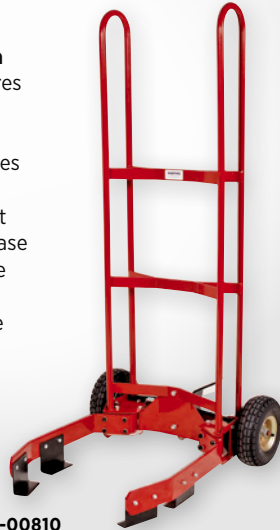

703-00810

ASCOT NO.	MFG. NO.	CAPACITY	DIMENSIONS
703-00810	MTC	8 to 10 tires	35" O.D. Max

WOODEN TIRE CART

- **Made of galvanized steel and high quality wood**
- Cast iron/rubber wheels
- Foot operated mechanism
- Adjustable clamps ▪ Able to carry passenger and light truck tires of up to 35" in diameter and move 6 to 8 tires at a time



703-00820

ASCOT NO.	MFG. NO.	DESCRIPTION
703-00820	MWTC	Wooden Tire Cart

SMART TIRE CART

- **Works on passenger 15" tires up to truck size 245/70R19.5**
- Moves mounted tires and wheel sets ▪ Moves tires in stacks of 8 to 10 high ▪ Stacks tires closer together than other carts which creates more storage space ▪ No foot pedals ▪ Great for loading and unloading trucks and containers ▪ Patented tilting action relieves stress off the user ▪ New push/pull system pushes the tires out of the SMART Cart arms without stress ▪ Fewer moving parts ▪ Easy to assemble ▪ "Patent Pending"



703-47147

ASCOT NO.	MFG. NO.	CAPACITY	DIMENSIONS
703-47147	G471147HD	8 to 10 tires	Handles sizes from 15" to truck size 245/70R19.5

TIRE CART REPLACEMENT TIRES/WHEELS

- **Flat-free foam design** ▪ **SIZE:** 10" x 3-1/2" ▪ Industrial inner & outer wheel bearings ▪ Sold as a pair of two
- Compatible with Martins tire carts



703-00818

ASCOT NO.	MFG. NO.	DESCRIPTION
703-00818	PU1005ASC	Tire Cart Replacement Tires/Wheels

AUTO & FLEET SERVICE // SHOP TOOLS, SUPPLIES & EQUIPMENT



➔ Floor Mats, Parts Return Bag, Seat Covers, Tire Covers

Interior Protection Products



The Slip-N-Grip® protection system provides total protection for the customer's car while being serviced:

- Covers hold fast to the upholstery: A patented process laminates two distinctly different plastics together - the top layer allows a person to easily slide into and out of the vehicle and the bottom, or gripping layer, keeps the seat cover in place
- Unique process eliminates static electric clinging and wrinkling.

A complete line of vehicle interior protection products are available along with a service center roll dispenser.

PLASTIC FLOOR MAT

- Slip-N-Grip® two-layer construction ensures plastic floor mat stays in place
- Impervious to water, oil, grease and most shop chemicals



399-98397

399-99432

ASCOT NO.	MFG. NO.	DESCRIPTION	QUANTITY
399-98397	M-FB-P9833-97	Plastic Floor Mat	500/case
399-99432	M-FG-P9943-02	Plastic Floor Mat	500/roll

PARTS RETURN BAG

- Heavy plastic bag for holding old removed parts you've replaced
- Keeps customer's vehicle and hands clean

ASCOT NO.	MFG. NO.	DESCRIPTION	SIZE
399-60098	P9943-56	Parts Return Bag	14" x 22"

PLASTIC SEAT COVER

- Slip-N-Grip® seat covers have two distinct layers: the bottom layer grips the seat to stay in place and the top layer is smooth to allow easy entry and exit from the vehicle
- Protects bucket, bench and split seats



399-99415

ASCOT NO.	MFG. NO.	DESCRIPTION	QUANTITY
399-99415	M-FG-P9943-15C	Plastic Seat Cover	500/roll

PLASTIC TIRE BAG

- 40% post-consumer recycled resin
- White film hides dirty tire
- Ideal for returning old tires or snow tires for storage



399-99429

ASCOT NO.	MFG. NO.	DESCRIPTION	SIZE	QUANTITY
399-99391	M-FG-P9933-91	Extra Large Tire Bag	47" x 48" x 1.25 Mil	125/roll
399-99429	M-FG-P9943-29C	Plastic Tire Bag	—	250/roll
399-99392	M-FG-P9933-92	SNG SUV Tire Bag	33" x 6x44"	250/roll

AUTO & FLEET SERVICE // SHOP TOOLS, SUPPLIES & EQUIPMENT

➔ Key Tags, Tire Labels, Steering Wheel Covers, Dispenser Racks



Interior Protection Products (cont.)

PLASTIC KEY TAG

- **Self-locking design holds keys secure** ▪ Large writing surface; holes are fully punched out eliminating "chads"
- Perfect for quickly tagging keys in a busy service area



399-99323

ASCOT NO.	MFG. NO.	DESCRIPTION	QUANTITY
399-99323	M-FB-P9933-23	Plastic Key Tag	1000/package

PAPER KEY TAG

- **Cost-effective, convenient solution for key control** ▪ Metal ring



399-98313

ASCOT NO.	MFG. NO.	DESCRIPTION	SIZE	QUANTITY
399-98313	M-FB-P9833-13	Paper Key Tag	1.5" x 2.75"	1,000/box

WORK TICKET HOLDER

- **Heavy-duty sewn nylon fabric handle ensures durability even in harsh conditions** ▪ Durable brass grommet increases strength



399-99302

ASCOT NO.	MFG. NO.	DESCRIPTION	SIZE	QUANTITY
399-99302	M-FB-P9933-02	Work Ticket Holder	10.5" x 14.5"	25/box

GENERIC ADHESIVE TIRE LABEL

- **Features sure-grip adhesive**
- Proper used tire labeling sells tires ▪ These labels will catch your customer's eye and promote sales

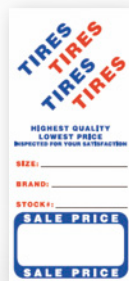

399-99479

ASCOT NO.	MFG. NO.	DESCRIPTION	QUANTITY
399-99479	M-FB-P9943-79	Generic Adhesive Tire Label	500/roll

STEERING WHEEL COVER

- **Keeps grease, dirt and other shop chemicals off of one of the most noticed and expensive parts on the car today** ▪ Reusable/disposable steering wheel covers are made of clear polyethylene with stretch elastic grip feature ▪ Elastic design is easier to apply and remove than stretch wrap covers ▪ Unique double-band steering wheel covers stays in place while allowing access to airbags



399-99433

- **STANDARD SIZE:** Covers virtually all passenger cars and light trucks. These covers are 5" wide and stretch to 24" covering steering wheels up to 15.2" in diameter
- **LARGE SIZE:** Fits the oversized steering wheels of heavy trucks and motor homes. These covers are 9" wide and they stretch to 40" covering steering wheels up to 25.4" in diameter

ASCOT NO.	MFG. NO.	DESCRIPTION	SIZE	QUANTITY
399-99433	M-FB-P9943-33	Double Band Steering Wheel Cover (Standard Size)	5" wide, stretch to 24"	500/box
399-99435	M-FB-P9943-35	Double Band Steering Wheel Cover (Large Size)	9" wide, stretch to 40"	250/box

PRODUCT DISPENSER SYSTEM

- **Promotes your professional image by displaying your complete line of car interior protection products where your customers can see you putting them in their car** ▪ Convenient roll dispenser work station provides organized storage, helps save employee time and shows your customers you care about their car



399-60000

ASCOT NO.	MFG. NO.	DESCRIPTION
399-60000	P9833-89A	Product Dispenser System

FLOOR DISPENSER RACK

- **Industry-leading dispenser system keeps products organized and within reach** ▪ Presents "We Care" image and promotes cleanliness ▪ Retention straps prevent free-rolling and locking casters keep dispenser in place ▪ Top tray holds paper floor mats and other service items while lower tray provides extra storage



399-98893

ASCOT NO.	MFG. NO.	DESCRIPTION
399-98893	M-FB-P9833-89B	Floor Dispenser Rack



➔ Floor Mats, Key Tags, Tire Labels

IMPRINTED PAPER FLOOR MATS

- **High bulk 60 pound paper imprinted with a "Thank You" message** ▪ Excellent protection for the plush interior of today's cars ▪ **SIZE:** 17" x 22" ▪ **QUANTITY:** 1,000 per box

ASCOT NO.	DESCRIPTION
399-00003	Imprinted Paper Floor Mats



399-00003

WAFFLE PAPER FLOOR MATS

- **Mat designed for wet applications** ▪ Made from a very durable packing material ▪ **SIZE:** 17" x 22" ▪ **QUANTITY:** 500 per bundle

ASCOT NO.	DESCRIPTION
399-00004	Waffle Paper Floor Mats



399-00004

PERSONALIZED PAPER FLOOR MATS

- **Either insert your logo where the footprints are or totally design a new layout** ▪ The stock is a high bulk 60 pound white sheet, size 17" x 22", with a one color imprint ▪ Minimum order of 3,000 ▪ Camera ready art must be supplied for all logos - one time artwork charge

ASCOT NO.	DESCRIPTION
399-00005	Personalized Paper Floor Mats



399-00005

BLUE FOOTPRINT PAPER FLOOR MAT

- **Blue footprint image** ▪ Lightly coated, high quality paper ▪ Printed with high quality UV ink ▪ **SIZE:** 17" x 19" ▪ **QUANTITY:** 500 per case ▪ **MADE IN THE USA**

ASCOT NO.	DESCRIPTION
399-76955	Blue Footprint Paper Floor Mat



399-76955

METAL RING KEY TAG

- **Save valuable time looking for customer keys** ▪ Keys can be immediately identified with this inexpensive 2-1/2" x 1-3/8" manila reinforced tag ▪ Plenty of room for name and license plate number



399-00010

ASCOT NO.	DESCRIPTION
399-00010	Metal Ring Key Tag

PLASTIC ARROW KEY TAG

- **Unique one piece key tag that attaches easily to the key ring with a hole for hanging on a board** ▪ Packaged 40 perforated sheets with 25 tags each ▪ 1000 per pack

ASCOT NO.	DESCRIPTION
399-00011	Plastic Arrow Key Tag

TIRE LABELS

- **2-1/2" x 6" label for easy identification of new, used and retreaded tires** ▪ Packed 500 per roll



601-00101

ASCOT NO.	MFG. NO.	DESCRIPTION
601-00101	TL-101	Tire Labels New-Used-Retread

AUTO & FLEET SERVICE // SHOP TOOLS, SUPPLIES & EQUIPMENT



➔ Stud Guns, Studding Equipment

Stud Guns & Studding Equipment

STUD GUN, STUDDING EQUIPMENT



ASCOT NO.	MFG. NO.	DESCRIPTION
458-00010	10-G	Stud Gun. Standard of the Industry. Automatic, Light weight
458-00002	KFP2	Stud Feeder. Fully automatic with 110 Volt motor, fast loading. Provides positive stud orientation. Feeds up to 225 studs per minute
458-04048	4048	Feederboy Stud Gun. Designed for fast feeding studs of the AS-9 Gun Attaches with screw clamp. Operates by manually turning the feeder cap
458-00005	K-5	Stud Feeder. INCLUDES: shield for gun. Welded steel construction with saddle
458-00500	K-500	Studding Equipment Kit. INCLUDES: K-5 stand, AS-9 gun, KFP2 automatic stud feeder

UGIGRIP®, SELF-ADJUSTING CARBIDE TIRE STUD

- Delivers full-time traction, increases the safety, convenience and security
- To order studs to best fit your customers' tire, use the TSMI number recommended by the tire manufacturer



SINGLE FLANGE STUDS:

TSMI Size	11	12	13	15	169	17	19
Overall Length	.345"	.375"	.470"	.520"	.585"	.515"	.635"
Jacket Dia.	.197"	.197"	.197"	.197"	.197"	.197"	.250"
Bottom Dia.	.354"	.354"	.354"	.354"	.354"	.354"	.354"
Nearest 32" to Hole Depth	11/32"	12/32"	13/32"	15/32"	16/32"	17/32"	19/32"

STUDDING EQUIPMENT

- Lightweight, reduces road wear ▪ Steel 12SL, 13SL & 16SL meet requirements for Washington, Oregon & Idaho

ASCOT NO.	STUDDING GUN	USE WITH STUDS NUMBERED
458-00010	10G	TSMI-11-12-13-15-16-17
458-00011	10T	TSMI-19-21

PARTS BREAKDOWN

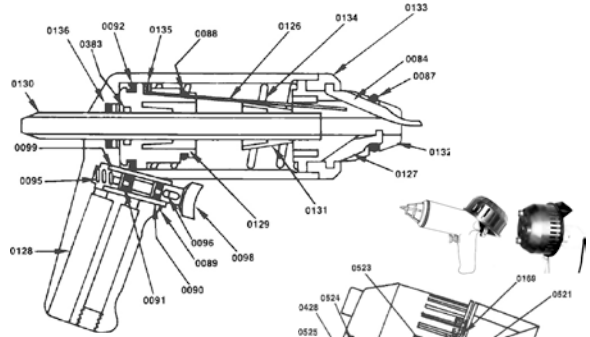

STUD GUN PARTS (AS-9 MODEL)

PART NO.	DESCRIPTION
0084	External Finger
0087	O-Ring
0088	O-Ring
0089	O-Ring
0090	O-Ring
0091	O-Ring
0092	Piston Cup
0095	Trigger Spring
0096	Trigger Pin
0098	Trigger
0099	Trigger Sleeve
0126	Pressing Spring
0127	Internal Finger
0128	Handle Body
0129	Piston
0130	Feed Tube
0131	Tapered Sleeve
0132	Head (Steel)
0133	Ring Nut
0134	Compression Spring
0135	Ring
0136	O-Ring
0383	Piston Cup

STUD FEEDER PARTS (KFP2 MODEL)

PART NO.	DESCRIPTION
0169	Deflector Spring
0172	Snap Ring
0173	Screw
0174	Washer
0175	Clamp
0180	Drive Shaft Pin
0428	Washer
0519	Feed Wheel
0520	Base Plate
0521	Retaining Ring
0522	Feed Tube
0523	Screw
0524	Shaft
0525	Hex Bolt

STUD GUN REPAIR & CONVERSION KITS

ASCOT NO.	STUDDING GUN	USE WITH STUDS NUMBERED
458-03810	0381	Tire Stud Mini Repair Kit. INCLUDES: (3) 0084 External Fingers; (1) 0087 O-ring; (1) 0088 O-ring; (3) 0126 Pressing Springs
458-03820	0382	Tire Stud Gun Large Repair Kit. INCLUDES: (6) 0126 Pressing Spring; (3) 0084 External Fingers; (2) 0087 O-ring; (2) 0088 O-ring; (1) 0092 Piston Cup; (1) 0136 O-ring
458-00911	00911	Conversion Kit. Converts AS-9 Gun to AS-11 Truck Model. INCLUDES: (1) 0401 Truck Feed Tube; (1) 0400 Truck Stud Gun Head; (3) 0127 Truck Stud Gun Internal Finger

AUTO & FLEET SERVICE // SHOP TOOLS, SUPPLIES & EQUIPMENT



➔ Balcrank Tank Packages, Electronic Control Handle, Pumps

Fluid Pumps

BALCRANK 3:1 TANK PACKAGE

INCLUDES:

- Panther 3:1 Pump
- Inlet hose
- Pressure Relief Kit
- FRL
- PGM-40 mechanical handle with flex extension
- Bung Adapter

ASCOT NO.	MFG. NO.	DESCRIPTION
322-32006	1132-006	3:1 Tank Package. INCLUDES: 1/2" x 30' Signature Series Hose Reel
329-11329	1132-009	3:1 Tank Package. INCLUDES: 1/2" x 50' Signature Series Hose Reel

BALCRANK 5:1 TANK PACKAGE

INCLUDES:

- Panther 5:1 Pump
- Inlet hose
- Pressure Relief Kit
- FRL
- PGM-40 mechanical handle with flex extension
- Bung Adapter

ASCOT NO.	MFG. NO.	DESCRIPTION
322-32007	1132-007	5:1 Tank Package. INCLUDES: 1/2" x 30' Signature Series Hose Reel
322-32010	1132-010	5:1 Tank Package. INCLUDES: 1/2" x 50' Signature Series Hose Reel

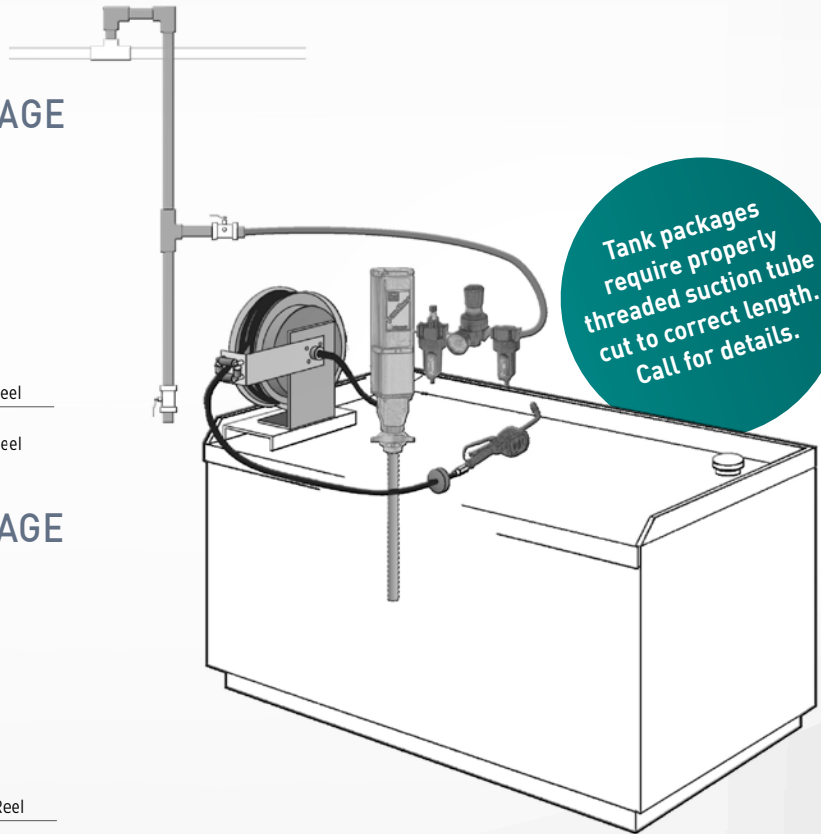

Tank packages require properly threaded suction tube cut to correct length. Call for details.

BALCRANK PGE-55 CONVERTIBLE ELECTRONIC CONTROL HANDLE

- **Heavy duty construction** ▪ Two outlet nozzle position (in-line or pistol grip) ▪ Oval gears for optimum accuracy ▪ Resettable batch totalizer; non-reset-table totalizer ▪ Resettable third totalizer to track daily or weekly usage
- Free-moving, ball bearing swivel ▪ Up to 8 gallons per minute (bare handle)
- Trigger guard included ▪ Models available with automatic and semi-automatic tip

322-30054



ASCOT NO.	MFG. NO.	TYPE	TIP
322-30054	3330-054	Rigid	Automatic
322-30055	3330-055	Flex	Automatic
322-30057	3330-057	Flex 90	Automatic
322-30058	3330-058	Bare	—
322-30059	3330-059	Straight*	Automatic
322-31014	3331-014	Straight	Semi-Automatic
322-31020	3331-020	Flex	Semi-Automatic
322-31012	3331-012	Bare	—

*Pistol Grip

BALCRANK PANTHER® 3:1 PUMPS

- **Double acting, true pump ratio**
- Balanced flow displacement
- Positive trip air valve prevents stalling
- Heavy duty air motor with thick wall housing and long stroke design
- Enlarged flow passages
- High performance check valves
- Smooth, quiet operation
- **Five year warranty, high value price point**
- Used for distribution to 500 Ft. and up to 3 reel simultaneous service - medium to high usage
- Pumps available up to 50:1

ASCOT NO.	MFG. NO.	DESCRIPTION
322-20015	1130-015	Balcrank Panther® 3:1 Pump



322-20015

AUTO & FLEET SERVICE // SHOP TOOLS, SUPPLIES & EQUIPMENT



Drains & Grease Guns

USED OIL SYSTEM

▪ When used with Balcrank's diaphragm pump 1120-013, this kit provides suction evacuation for the 4110-010 Spillguard Drain ▪ **INCLUDES:** Wall bracket, air hose, suction hose and fluid hose with dry-break coupler



ASCOT NO.	MFG. NO.	DESCRIPTION
322-41110	4110-010	Spillguard Drain
324-11213	1120-013S	1" Diaphragm Pump
329-11211	1121-011	1" Outfit Kit. INCLUDES: 1120-013 & 4140-015
329-11212	1121-012	KIT INCLUDES: 1120-019 (Diaphragm Pump), 4140-026 (Oil Kit)

ROUGHNECK II™ SERIES SELF EVACUATING DRAINS

▪ Drain used oil or antifreeze into the 23 gallon reservoir, then connect to low pressure air hose to evacuate oil or antifreeze into any bulk storage tank
 ▪ No pump required ▪ Features 19.25" bowl, quick height adjustment, sight gauge, patented automatic evacuation valve, regulated air inlet with safety valve, tank handle, large carriage wheels and durable powder coat finish
 ▪ Antifreeze drains painted with green powder coat



ASCOT NO.	MFG. NO.	DESCRIPTION
322-10022	4110-022	Used Oil Drain
322-10023	4110-023	Used Antifreeze Drain

GREASE GUNS

▪ When used with Balcrank's diaphragm pump 1120-013, this kit provides suction evacuation for the 4110-010 Spillguard Drain ▪ **INCLUDES:** Wall bracket, air hose, suction hose and fluid hose with dry-break coupler

ASCOT NO.	MFG. NO.	DESCRIPTION
323-52006	5200-006	Lever style Grease Gun
323-52007	5200-007	Pistol Style Grease Gun
323-52008	5200-008	Air Operated Grease Gun



Complete line of Oil & Grease Reels Available! Call for details.



Waste Oil Drains

SUPER TRUCK DRAIN ON WHEELS

- **Rugged heavy duty plastic tub for draining a large capacity crankcase**
- Resistant to corrosives found in oils
- Holds 60 quarts to the rim
- Heavy duty casters fit into built-in fasteners for maneuverability
- Sturdy formed wire handle for easy moving
- **OVERALL HEIGHT: 10"; WIDTH: 24" I.D.; LENGTH: 43"**



322-19122

ASCOT NO.	MFG. NO.	DESCRIPTION
322-19122	19122	Super Truck Drain on Wheels

TRANSMISSION DRAIN FUNNEL

- **22" by 23" heavy duty plastic lift drain funnel**
- Extends the catch area of any lift drain
- Funnel catches any loose parts
- Prevents parts from falling through drain



322-17892

ASCOT NO.	MFG. NO.	DESCRIPTION
322-17892	17892	Transmission Drain Funnel

DUNK TANK

- **Heavy duty plastic tire and tube test tank**
- Features pyramid type ribs for extra support to prevent bowing
- Handles passenger tire sizes to wide oval and light duty truck tires



322-19822

ASCOT NO.	MFG. NO.	DESCRIPTION
322-19822	2400-10	Passenger Car
322-02444	240044	SUV/Light Truck

MULTI-DRAIN TUB

- **30-quart, all purpose, heavy duty, plastic drain tub**
- For draining radiator, crankcase, transmission differential
- Accommodate autos and trucks
- Apron for washing and sorting parts



322-17922

ASCOT NO.	MFG. NO.	DESCRIPTION
322-17922	17922	Multi-Drain Tub

Oil Drains, Dunk Tank, Lube Tank

COLLECTION SPILL-PROOF RECOVERY DRAIN PAN

- **Heavy duty construction and an outstanding new concept for transfer of liquids**
- Holds 4-1/2 gallons
- For auto, home and industry
- Resistant to chemicals & solvents
- Made of durable high-density polyethylene
- 3 large openings lead liquid into 1" wide diameter spout for quick and easy pouring



322-17942



322-17952

ASCOT NO.	MFG. NO.	DESCRIPTION
322-17942	17942	Black Drain Pan
322-17952	17952	Green Drain Pan

SINGLE WALL UL-142 CUBE LUBE TANK

- **UL listed tanks - double wall**
- If tank is for used oil, a high level tank monitor is recommended



ASCOT NO.	MFG. NO.	DIMENSIONS (H X W X D)	THICKNESS	APPROX. WEIGHT
322-00125	DW125	38"x32"x26"	12 Gauge	170 Lbs.
322-00200	DW200	36"x60"x22"	12 Gauge	220 Lbs.
322-00201	DW200V	60"x36"x22"	12 Gauge	220 Lbs.
322-00250	DW250	34"x60"x28"	12 Gauge	290 Lbs.
322-00251	DW250V	60"x34"x28"	12 Gauge	290 Lbs.
322-00300	DW300	38"x60"x31"	12 Gauge	325 Lbs.
322-00301	DW300V	60"x38"x31"	12 Gauge	325 Lbs.
322-00350	DW350V	60"x41"x31"	12 Gauge	350 Lbs.
322-00500	DW500	60"x60"x33"	12 Gauge	450 Lbs.
322-00650	DW650	60"x78"x33"	10 Gauge	730 Lbs.
322-00750	DW750	60"x90"x33"	10 Gauge	820 Lbs.
322-01000	DW1000	60"x118"x33"	10 Gauge	1,025 Lbs.

Oil Drains, Containment Vessel, Drum Funnel

Waste Oil Drains (cont.)

8-GALLON OIL LIFT DRAIN

▪ **8-gallon capacity** ▪ Spout for evacuation ▪ Hand grips on bottom and top for ease in evacuation ▪ Four 3-1/2" ball bearing wheels ▪ Height adjusts from 48" to 71" ▪ Polyethylene body is translucent for easy viewing of oil level

322-24020



ASCOT NO.	MFG. NO.	CAPACITY	HEIGHT (MAX.)	HEIGHT (MIN.)
322-24020	2400-20	8-Gal.	71"	48"

LOW BOY OIL DRAIN

▪ **Rolls under trucks or buses to drain oil or antifreeze with ease** ▪ Constructed of heavy duty polyethylene that will resist rust, dents, automotive fluids and other chemicals ▪ Gravity drain valve is recessed to protect it from damage and a wire screen in the pan prevents foreign matter from entering into the reservoir

322-24037



ASCOT NO.	MFG. NO.	CAPACITY	DESCRIPTION
322-24034	2400-34	17 Gallon	Low Boy Oil Drain
322-24037	2400-37	17 Gallon	Low Boy Oil Drain w/115V Evac

DOUBLE DRUM CONTAINMENT VESSEL

▪ **Perfect solution for storing your chemical drums** ▪ Drum pallets are designed so that hazardous spills can be safely contained in pallet basin, not on your floors or in the soil ▪ Pallets hold two 55 gallon drums ▪ Convenient forklift entry ▪ *Designed for in-plant use, not for transport*



322-24016

ASCOT NO.	MFG. NO.	DESCRIPTION
322-24016	SP1006A	Chemical Drum Storage Unit

18-GALLON OIL LIFT DRAIN

▪ **18-gallon capacity** ▪ Four 3-1/2" ball bearing wheels ▪ 3/4" evacuation valve ▪ Spout for evacuation ▪ Hand grips on bottom and top ▪ Height adjusts from 48" to 71" ▪ Polyethylene body is translucent for easy viewing of oil level ▪ *Oil Drain Pump not included*

322-24026



ASCOT NO.	MFG. NO.	CAPACITY	HEIGHT (MAX.)	HEIGHT (MIN.)
322-24019	2400-19	18-Gal.	71"	48"
322-24026	2400-26	Oil Drain Pump		

DRUM FUNNEL

▪ **Eliminates overspills while pouring** ▪ Large surface area permits drainage of multiple containers simultaneously ▪ **HIGHLY DURABLE:** Will resist rust, dents and other chemicals and will give many years of trouble-free service ▪ Fits all types of 55-gallon drums ▪ Patented design ▪ **COLOR:** yellow

322-24014

ASCOT NO.	MFG. NO.	DESCRIPTION
322-24014	2400-14	Drum Funnel



OIL LIFT CADDY

▪ **Unique new way to drain an oil or hydraulic fluid tank** ▪ 28-gallon capacity ▪ Molded-in baffle for strength and durability ▪ Rolls easily on pneumatic tires with nylon bearings ▪ Designed for easy balance and movement ▪ Orange polyethylene body is translucent for easy viewing of oil level ▪ 18" diameter funnel height adjusts from 47" to 72" ▪ Drains through 3/4" faucet

329-93249



ASCOT NO.	MFG. NO.	DESCRIPTION
329-93249	932409IP	Oil Lift Caddy, 28-Gallon

AUTO & FLEET SERVICE // LUBRICATION EQUIPMENT

➔ Measuring Containers, Radiator Fillers, Anti-Freeze Bibb, Oil Filter Crushers

Oil Accessories

MEASURING CONTAINERS

- Heavy duty helpers to handle the most demanding jobs
- Large handle and wide base
- 5-quart capacity



329-18110

ASCOT NO.	MFG. NO.	DESCRIPTION	CAPACITY
329-18110	18110	Measuring Container	5 Quarts

RADIATOR FILLERS

- Long curved spout, balanced shape and handle positions
- Weather resistant plastic
- 12-quart capacity



329-00505

ASCOT NO.	MFG. NO.	DESCRIPTION	CAPACITY
329-00505	6110-010	Black Plastic Radiator Filler	12 Quarts



Please contact us for further details regarding **LUBRICATION EQUIPMENT.**

WATER/ANTI-FREEZE BIBB

- Durable, full volume dispense nozzle for water, windshield wash and antifreeze
- 1/4" NPT female inlet



329-18685

ASCOT NO.	MFG. NO.	DESCRIPTION
329-18685	3340-014	Water/Anti-Freeze Bib

AIR OPERATED OIL FILTER CRUSHERS

- Air/hydraulic operation for maximum crushing force
- Unitized construction for easy maintenance
- Door channel prevents drips and leakage
- Locator pins help center filter in the chamber
- Safety switch prevents operation when door is open
- Optional wall bracket and floor stands available
- Requires FRL-1 air filter/regulator/lubricator (not included)



322-10094

SAFETY SWITCH

ASCOT NO.	MFG. NO.	DESCRIPTION
322-10094	AFC100-94	Automotive 10-Ton Air Operated Oil Filter Crusher
322-15094	HDC150-94	Heavy Duty Truck 15-Ton Air Operated Oil Filter Crusher

➔ Face Protection, Hearing Protection, Safety & Traffic Control Products

Safety Products

EYE AND FACE PROTECTION



396-01318

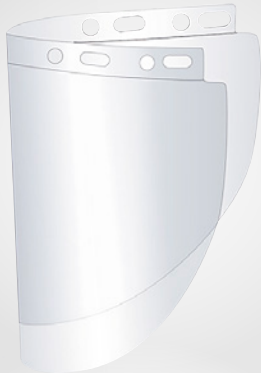

396-31844



396-33641

ASCOT NO.	DESCRIPTION
396-01318	Headgear. Lightweight Thermoplastic. Snap-On Adjustable Suspension And Crown Strap. Spark Deflector
396-31844	Jackson Clear Visor. 12" x 8" x .04". Bound Acetate
396-33461	Crews Tomahawk Glasses. Red, Blue, White. Clear Lens
396-81095	Particulate Respirator. Adjustable Noseclip For Secure Fit and Secure Seal (Not Pictured)

HEARING PROTECTION



396-27231



396-27233

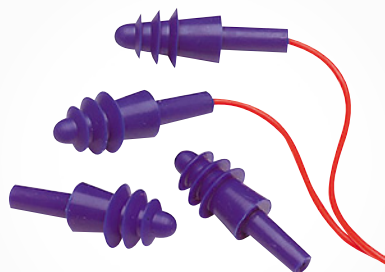

396-27521

ASCOT NO.	DESCRIPTION
396-27231	E-A-R Classic Plug. Pillow Pack. 200 per Box
396-27233	E-A-R Muff. Three Position Muff Can Be Worn Over The Head, Behind the Head Or Under The Chin
396-27521	Airsoft Earplug. With Vinyl Cord. 100/DS

SAFETY & TRAFFIC CONTROL PRODUCTS



396-20100

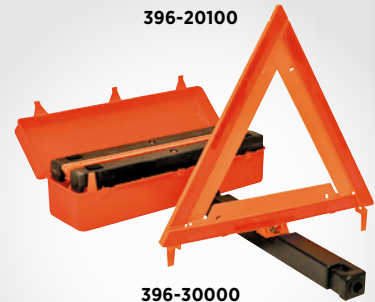

396-30000



396-66227

ASCOT NO.	DESCRIPTION
396-20100	Safety Vest. Orange Mesh Style Safety Vest with Reflective Strips
396-30000	Highway Warning Triangle Kit. Reflective And Easy To Set Up. Contains 3 Triangles In Plastic Case
396-66227	2-1/2 Lb. Fire Extinguisher w/ Wall Hook

AUTO & FLEET SERVICE // SAFETY PRODUCTS

➔ First Aid, Driveway Signal & Hose, DOT Conspicuity Tape

FIRST AID PRODUCT



396-61316

ASCOT NO.	DESCRIPTION
396-30100	First Aid Kit, 10 Unit Kit. Meets ANSI Standards For Size And Color Coding. Red Tear Strip For Quick, Efficient Opening
396-61316	Healer Eyewash Station. W/2-16 Oz. Bottles

DRIVEWAY SIGNAL AND HOSE

▪ Know when you have a customer at the pumps with this 6" diameter driveway signal bell ▪ Completely self-contained unit makes installation easy ▪ Each signal is manufactured to give you a signal that will perform under prolonged use



392-00805

ASCOT NO.	MFG. NO.	DESCRIPTION
392-00805	805	Driveway Signal - 110V 6" Dia. Bell
392-00838	838	50' Coil of Driveway Signal Hose
392-00839	839	300' Coil of Driveway Signal Hose



DOT CONSPICUITY TAPE

▪ Meets all Federal and State certifications ▪ Micro prismatic technology ▪ Thin and flexible ▪ 10-year durability



396-62150

ASCOT NO.	MFG. NO.	DESCRIPTION
396-62150	CT6R6W2150	2" x 150' (6" Red, 6" Silver)
396-72150	CT11R7W2150	2" x 150' (11" Red, 7" Silver)
396-82150	CTR2150	2" x 150' Solid Red
396-92150	CTW 2150	2" x 150' Solid Silver



AUTO & FLEET SERVICE // SAFETY PRODUCTS



Wheel Chocks

RUBBER WHEEL CHOCK

▪ **Durable rubber construction** ▪ Features an eye bolt for chain or rope attachment ▪ Ribbed pyramid design
 ▪ Either side of wheel chock can be positioned against the tire ▪ Sold individually ▪ **WEIGHT:** 10 Lbs. (4.5kg)



396-15300

ASCOT NO.	MFG. NO.	DESCRIPTION
396-15300	15300	Rubber Wheel Chock

OTR WHEEL CHOCK

▪ **DIMENSIONS:** 12" x 10" x 12" ▪ Designed for heavy duty truck and mining equipment ▪ 20" rope attached for convenience ▪ **NET WEIGHT:** 27.5 lbs.



396-00102

ASCOT NO.	MFG. NO.	DESCRIPTION
396-00102	TS102	OTR Wheel Chock

URETHANE WHEEL CHOCKS

▪ **SOLID LIGHTWEIGHT CONSTRUCTION** ▪ High impact urethane material ▪ Non-conductive, no threat to puncture the tire ▪ Durable, lightweight and easy to use ▪ Extensively field tested



396-15336



396-15337



396-15338



396-15339



396-15342



396-15353

ASCOT NO.	MFG. NO.	TIRE SIZE	DIMENSIONS (LXWXH)	WEIGHT
396-15336	15336	35" to 55" (90 cm to 140 cm)	13.3" x 8.6" x 7.8" (34 cm x 22 cm x 20 cm)	7.7 lbs. (3.5 kg)
396-15337	15337	47" to 86" (120 cm to 220 cm)	18" x 12" x 9" (47.5 cm x 30.5 cm x 22.5 cm)	13 lbs. (6 kg)
396-15338	15338	70" to 118" (180 cm to 300 cm)	22.5" x 13" x 14" (57 cm x 34 cm x 35.5 cm)	19.8 lbs. (9 kg)
396-15339	15339	110" to 165" (280 cm to 420 cm)	26.7" x 13" x 14" (68 cm x 33.7 cm x 35.5 cm)	30.86 lbs. (14 kg)
396-15342	15342	86" to 137.8" (220 cm to 350 cm)	24" x 13.5" x 12" (62.1 cm x 34.3 cm x 32.3 cm)	24.3 lbs. (11 kg)
396-15353	15353	47" to 70" (120 cm to 180 cm)	13.38" x 9.84" x 7.8" (34 cm x 25 cm x 22.5 cm)	13.66 lbs. (6.2 kg)



Rubber Blocks & Lift Pads

RUBBER LIFT PAD (5" ROUND)

▪ **RUBBER PAD DIMENSIONS:** 5" round ▪ Kit of four rubber pads ▪ Replacement pads for Nussbaum lifts

ASCOT NO.	MFG. NO.	DESCRIPTION
309-00003	JOK03M	Rubber Lift Pad - 5" Round

309-00003



RUBBER LIFT PAD (3.25" X 4")

▪ **RUBBER PAD DIMENSIONS:** 3.25" x 4" ▪ Kit of four rubber pads ▪ Replacement pads for Rotary SPO10, SPO12 lifts

ASCOT NO.	MFG. NO.	DESCRIPTION
309-00022	JOK22D	Rubber Lift Pad - 3.25" x 4"

309-00022



RUBBER LIFT PAD (4" X 5")

▪ **RUBBER PAD DIMENSIONS:** 4" x 5" ▪ Kit of four rubber pads ▪ Replacement pads for Ammco, Ben Pearson lifts

ASCOT NO.	MFG. NO.	DESCRIPTION
309-00005	JOK05M	Rubber Lift Pad - 4" x 5"

309-00005



RUBBER LIFT PAD (5.25" ROUND)

▪ **RUBBER PAD DIMENSIONS:** 5.25" round ▪ Kit of four rubber pads ▪ Replacement pads for Challenger CL10, Quality lifts

ASCOT NO.	MFG. NO.	DESCRIPTION
309-00014	JOK14O	Rubber Lift Pad - 5.25" Round

309-00014



RUBBER LIFT PAD (5" X 5")

▪ **RUBBER PAD DIMENSIONS:** 5" x 5" ▪ Kit of four rubber pads ▪ Replacement pads for Forward, Worth, American, Gemini, Grand, Tuxedo, Eagle, Whip lifts

ASCOT NO.	MFG. NO.	DESCRIPTION
309-00007	JOK07M	Rubber Lift Pad - 5" x 5"

309-00007



RUBBER BLOCK 1.5"

▪ **RUBBER BLOCK DIMENSIONS:** 6" x 4" ▪ Kit of four 1.5" rubber blocks ▪ Spacer blocks for Rotary Airjacks and all Mid-Rise pad lifts

ASCOT NO.	MFG. NO.	DESCRIPTION
309-00011	JORB-1	Rubber Block 1.5"

309-00011



RUBBER LIFT PAD (4" X 4")

▪ **RUBBER PAD DIMENSIONS:** 4" x 4" ▪ Kit of four rubber pads ▪ Replacement pads for Challenger CL9 and CL10 lifts

ASCOT NO.	MFG. NO.	DESCRIPTION
309-00009	JOK09O	Rubber Lift Pad - 4" x 4"

309-00009



RUBBER BLOCK 3"

▪ **RUBBER BLOCK DIMENSIONS:** 6" x 4" ▪ Kit of four 3" rubber blocks ▪ Spacer blocks for Rotary Airjacks and all Mid-Rise pad lifts

ASCOT NO.	MFG. NO.	DESCRIPTION
309-00009	JOK09O	Rubber Lift Pad - 4" x 4"

309-00009



➔ Nitrile Gloves, Miscellaneous Hand Protective Gloves

Mechanic's Gloves

NITRILE GLOVES

- For industrial and automotive applications
- Powder-free ▪ **THICKNESS:** 6 mil
- Thick material for extra comfort and elasticity ▪ **QUANTITY:** 100 per box, 10 boxes per case



ASCOT NO.	MFG. NO.	DESCRIPTION
396-00101	BLK-S	Black Nitrile Glove (Small)
396-01102	BLK-M	Black Nitrile Glove (Medium)
396-00103	BLK-L	Black Nitrile Glove (Large)
396-00104	BLK-XL	Black Nitrile Glove (XL)
396-00105	BLK-XXL	Black Nitrile Glove (XXL)
396-00201	BLU-S	Blue Nitrile Glove (Small)
396-00202	BLU-M	Blue Nitrile Glove (Medium)
396-00203	BLU-L	Blue Nitrile Glove (Large)
396-00204	BLU-XL	Blue Nitrile Glove (XL)
396-00205	BLU-XXL	Blue Nitrile Glove (XXL)

MISCELLANEOUS HAND PROTECTIVE GLOVES



396-06780

396-40314

All gloves are available in small, medium, large, X-Large and XX-Large. Please indicate size when ordering.



396-40317

396-55220

ASCOT NO.	DESCRIPTION
396-06780	Wet Grip Neoprene Glove. Protects Against Acids, Caustics, Oils, Greases And Many Solvents. 5-Piece Flannel Liner
396-40314	Hot Mill Glove. Gauntlet, Domestic
396-40315	Hot Mill Glove. Gauntlet Starched Cuff with Rayon Lining
396-40317	Power Grip with Latex Premium Grip
396-55220	Leather Palm Glove with Safety Cuff, Elastic

NITRILE PROTECTIVE GLOVES



ASCOT NO.	DESCRIPTION
396-02004	Large Nitrile Pro Gloves

396-02004



TIRE BUDDY GLOVES

- High-abrasion resistant palm ▪ EVA foam padding in lower portion of palm to reduce fatigue & injuries ▪ Tough Spandex top material ▪ Open elastic cuff allows for easy access



396-10309

ASCOT NO.	MFG. NO.	DESCRIPTION
396-10309	103-09	Medium Tire Buddy Gloves
396-10310	103-10	Large Tire Buddy Gloves
396-10311	103-11	XLarge Tire Buddy Gloves
396-10312	103-12	XXLarge Tire Buddy Gloves

RINGERS NITRILE DIPPED GLOVES

- Ergonomically pre-curved
- Nitrile dipped breatheable shell ▪ Superior grip on wet & dry surfaces



396-01309

ASCOT NO.	MFG. NO.	DESCRIPTION
396-01309	013-09	Medium Nitrile Dipped Gloves
396-01310	013-10	Large Nitrile Dipped Gloves
396-01311	013-11	XLarge Nitrile Dipped Gloves

BLACK RAVEN POWDER FREE NITRILE GLOVES

- Powder-free nitrile - No natural rubber latex proteins
- Disposable
- Textured grip for superior holding
- 6 mil. thickness allows for high-resistance to puncture & abrasion ▪ 100 gloves per box



396-66516

ASCOT NO.	MFG. NO.	DESCRIPTION
396-66516	66516	Small Black Raven Nitrile Gloves
396-66517	66517	Medium Black Raven Nitrile Gloves
396-66518	66518	Large Black Raven Nitrile Gloves
396-66519	66519	XLarge Black Raven Nitrile Gloves
396-66520	66520	XXLarge Black Raven Nitrile Gloves